



HURRICANE 500E

HURRICANE 500E SPECIFICATIONS

• TRAILER MOUNTED

Chassis - Tandem 7000# axles, 4" x 6" rectangular tube frame; four, 8 lug P235R- 16 ten ply, radials. DOT lighting with electric brakes

• POWER SOURCE

John Deere turbo-charged diesel engine, 6 cylinder, 170 HP @ 2400 RPM

• P.T.O (clutch)

Twin Disc 11.5"

• VACUUM AIR FLOW (blower)

Roots Dresser 2350 CFM capable of 27" Hg, 5 belt driven, with guard

• FILTRATION SYSTEM

Cyclonic separation. Baghouse - 37 Teflon coated, quick change filter bags with continuous reverse pulse air cleaning. High efficiency blower safety filter.

• HYDRAULICS

3.5 GPM, 1800 PSI, 12 volt electric pump

• ENCLOSURE

Lockable steel shroud over engine

• INSTRUMENT PANEL (fully enclosed)

12 volt key start, Murphy safety switch (low oil pressure/ high water temperature-auto shut down)

Gauges: oil pressure, water temperature, ammeter, tachometer with hour meter, air pulse on/off switch, material vacuum & dump time controls

• AIR COMPRESSOR

Direct drive Midland twin cylinder; water cooled and oil pressure fed. Midland air dryer with electronic heater. AMSE certified air tank mounted on vibration isolators.

STANDARD EQUIPMENT

- Paint-one color (custom lettering available)
- Wet or dry operation
- Tool box
- Automatic cone vibrator
- 100 gallon fuel tank
- Adjustable pintle hook
- Emergency stop button

OPTIONS

- Spare tire & carrier
- Cold weather package
- HEPA filtration
- Slide gate discharge
- Auxiliary 50 gallon fuel tank
- Hydraulic lift leg to level trailer
- 16" manhole on baghouse
- High reach package for discharge up to 11'
- Auger in hopper (cone)
- Auxiliary air hose 120 PSI
- Skid mount
- Hydraulic surge brakes

Information in this document
is subject to change without notice.



Industrial Air Solutions, Inc.
6300 Limousine Drive, Suite 120
Raleigh, NC 27617

Toll Free (USA) 877-844-3293

Fax 919-518-1667

E-mail info@industrialairsolutions.com

www.industrialairsolutions.com

24' 4"



HURRICANE 500E

DIMENSIONS

WEIGHT 10,500 lbs.

WIDTH 8' 3"

16'

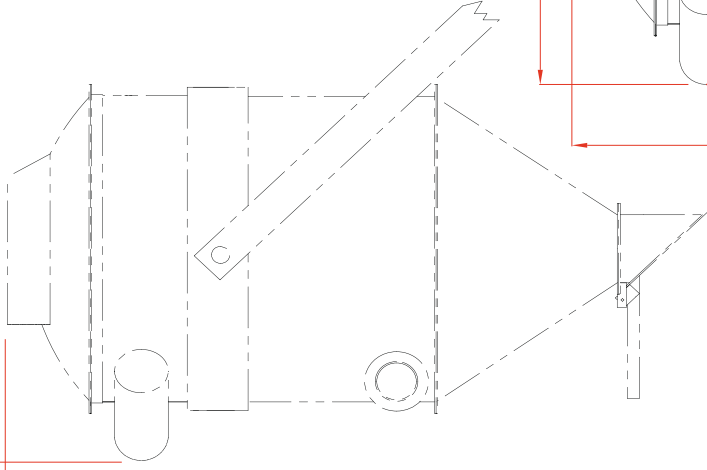

18' 9"

8' 9"

11' 1"

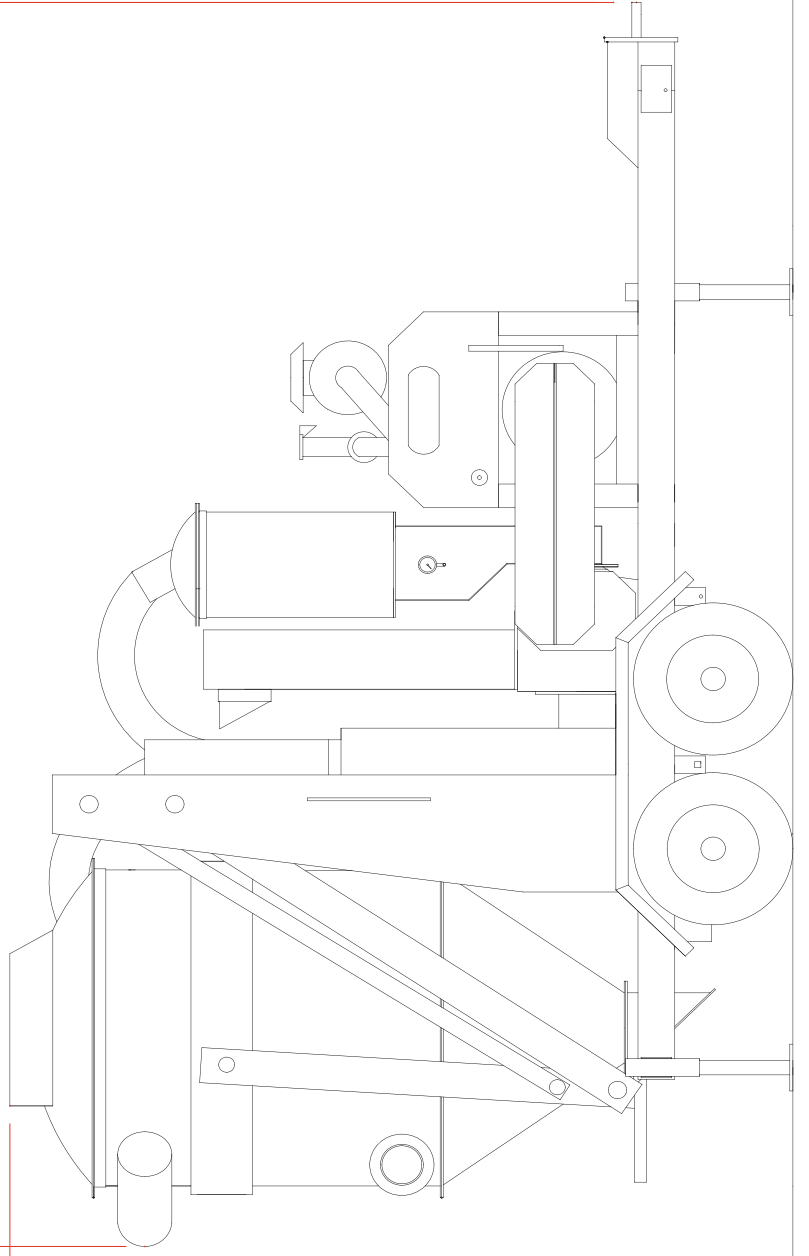

29 1/2"