



HURRICANE 655

HURRICANE 655 SPECIFICATIONS

• TRAILER MOUNTED

Chassis - Tandem 7000# axles, 4" x 6" rectangular tube frame; four, 8 lug P245R-16 ten ply, steel belted radials. DOT lighting with electric brakes. Enclosed trailer light wiring harness, sealed junction boxes.

• POWER SOURCE

John Deere turbo-charged diesel engine, 6 cylinder, 170 HP @ 2400 RPM

• P.T.O (clutch)

Rockford 11.5"

• VACUUM AIR FLOW (blower)

Roots Dresser 3660 CFM capable of 16" Hg, 5 belt driven, with guard and adjustable idler pulley for belt tension

• FILTRATION SYSTEM

Cyclonic separation. Baghouse - 37 Teflon coated, quick change filter bags with 5 station continuous reverse pulse air cleaning. High efficiency blower safety filter.

• HYDRAULICS

3.5 GPM, 1800 PSI, direct drive

• ENCLOSURE

Lockable fiberglass shroud over all major components

• INSTRUMENT PANEL (fully enclosed)

12 volt key start, Murphy safety switch (low oil pressure/ high water temperature-auto shut down)

Gauges: oil pressure, air pressure, water temperature, ammeter, tachometer with hour meter, air pulse on/off switch, material vacuum & dump time controls

• AIR COMPRESSOR

Direct drive Midland twin cylinder; water cooled and oil pressure fed. Midland air dryer with electronic heater. AMSE certified air tank mounted on vibration isolators.

STANDARD EQUIPMENT

- Paint-one color (custom lettering available)
- Wet or dry operation
- Emergency stop button
- Automatic cone vibrator
- 100 gallon fuel tank
- Hydraulic lift leg to level trailer
- Tool box
- Auxiliary air hose 120 PSI
- Spare tire & carrier
- 16" manhole on baghouse

OPTIONS

- Skid mount
- Cold weather package
- Auger in hopper (cone)
- Slide gate discharge
- Hydraulic surge brakes
- Auxiliary 50 gallon fuel tank
- HEPA filtration
- High reach package for discharge up to 11'

Information in this document
is subject to change without notice.



Industrial Air Solutions, Inc.
6300 Limousine Drive, Suite 120
Raleigh, NC 27617

Toll Free (USA) 877-844-3293

Fax 919-518-1667

E-mail info@industrialairsolutions.com

www.industrialairsolutions.com

24' 4"



HURRICANE 655

DIMENSIONS

WEIGHT 10,500 lbs.

WIDTH 8'3"

16'

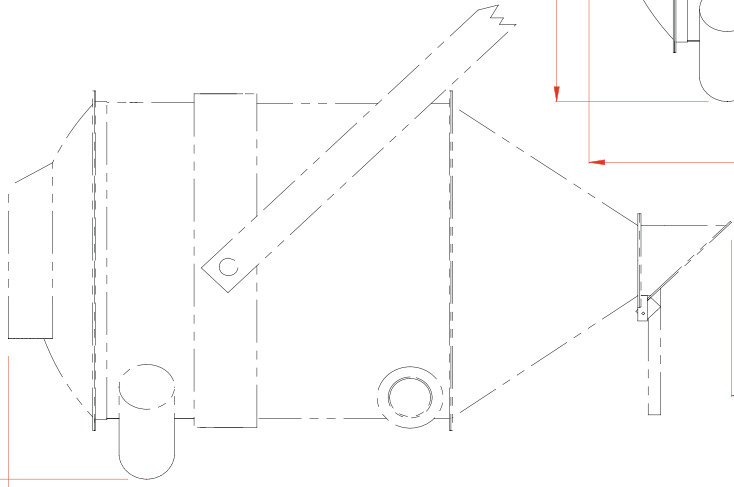

18' 9"

8' 9"

11' 1"

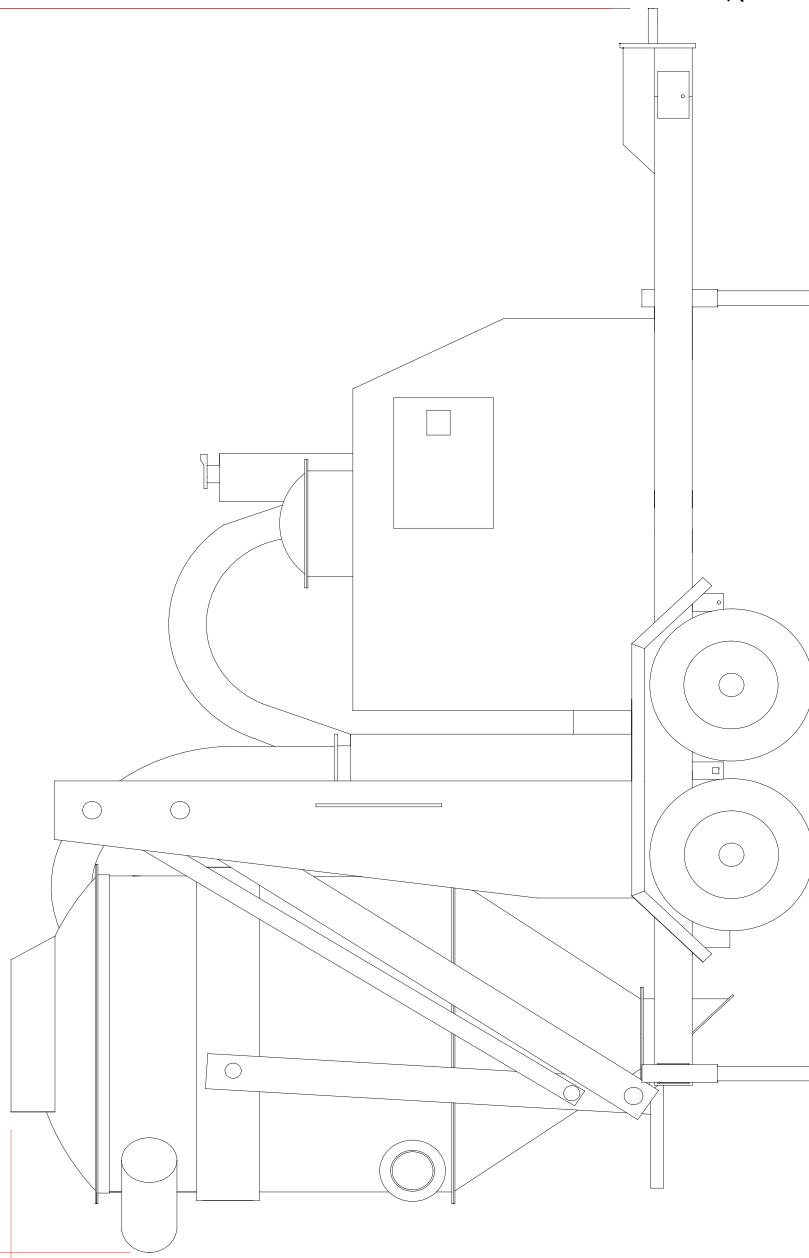

29 1/2"