

PROJECT:

FOR APPROVAL

CERTIFIED

MODEL PL25 PORTABLE VACUUM SYSTEM

STANDARD FEATURES:

1. 600 ICFM @ 14" Hg. CONTINUOUS
2. SUTORBILT 5L VACUUM PRODUCER
3. 25 HP LEESON MOTOR
4. NINETEEN (19) FILTER BAGS WITH 85 SF FILTER AREA
5. **99.9% AT 0.4 MICRON, STANDARD**
6. EFFECTIVE, EXTERNAL BAG SHAKER
7. 35.5 SF INLINE FILTER, STANDARD
8. 40 CF MATERIAL STORAGE
9. SILO TYPE, ABRASION RESISTANT INLET
10. **CUSTOM TUNED SILENCER, UNDER 85 DBA @ 3FT!**

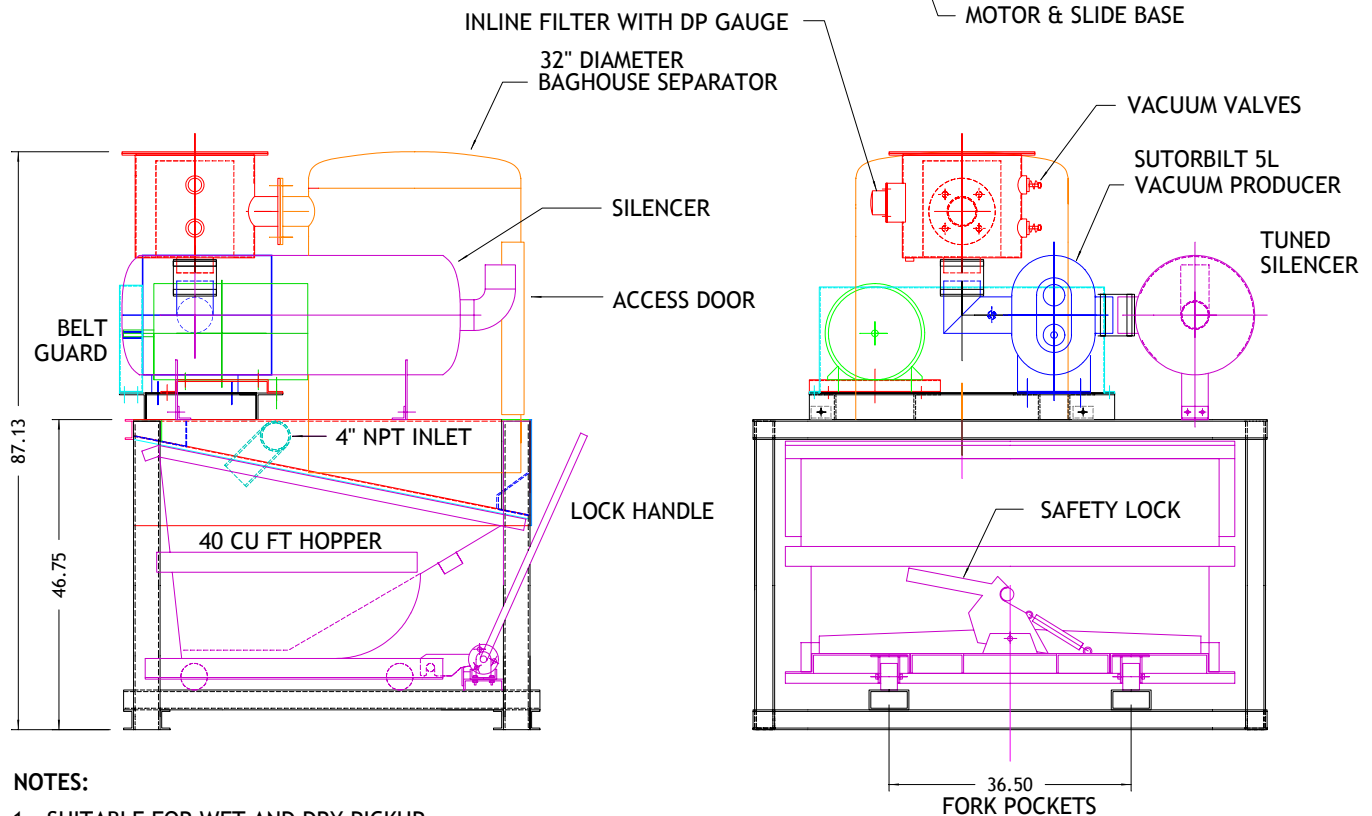
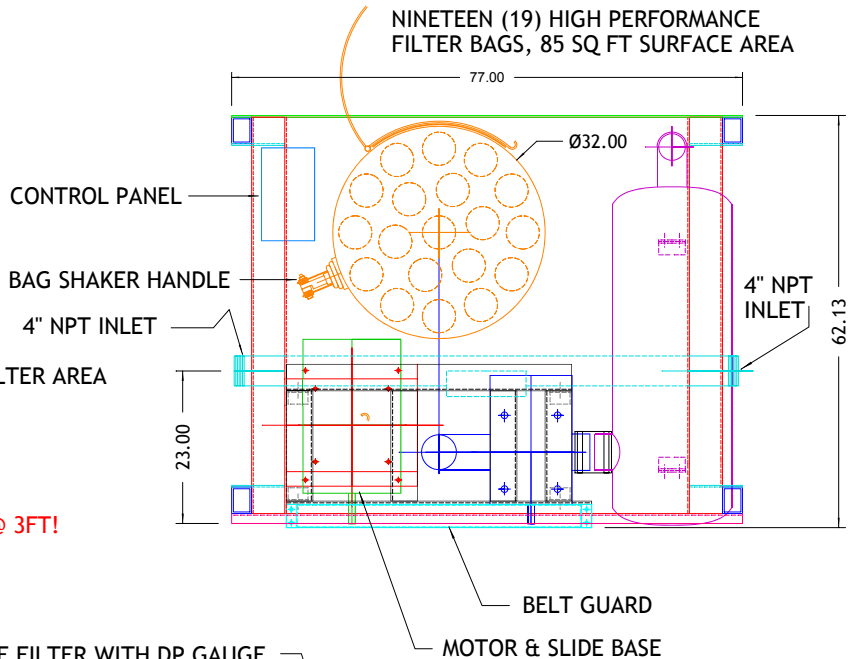

NOTES:

1. SUITABLE FOR WET AND DRY PICKUP
2. EXPECT 130 - 160 LBS/MIN PICKUP WITH 3.0" HOSE 25 FT LONG
3. WILL SUPPORT A FIXED PIPE NETWORK UP TO 400 FT LONG WITHOUT MODIFICATION
4. PAINTED PRIME BASE COAT AND TWO TOP COATS OF ENAMEL

**WARNING: VACUUM PRODUCERS THAT CLAIM TO ACHIEVE 18" Hg. CAN *NOT* MAINTAIN VACUUM AT THAT LEVEL WITHOUT OVERHEATING!
ENSURE YOU ASK FOR A WRITTEN PERFORMANCE GUARANTY THAT SPECIFIES 1 HOUR SEALED RUN TIME**

Industrial Air Solutions
Raleigh, NC 877-844-3293

01

10 DEC 02

Rev.

Date

FOR REVIEW

DATE:

DRAWN BY: KRW

SCALE: NTS

DRAWING No. Rev.

ND2002152 00

PAGE 1 OF 1